

OPEN CHURCH

making better access



An information leaflet from the
Committee on Church Art and Architecture
of the Church of Scotland
Aug 2001, updated Mar 2003, Nov 2005

||

It can be galling and disturbing to people who, used to making their own way, find themselves having to be helped to negotiate obstacles. It can be difficult for those who enjoy full mobility to appreciate the small setbacks of being forced to give up one's initiative.

||

The illustrations on pages 8 and 9 are by Douglas Laird, Convener of the Committee on Artistic Matters. The image on the title page is from a photograph by Antonia Reeve of an entrance in 'The Hub', the former Highland Tolbooth Church in Edinburgh, from page 56 of Issue 63 of Church Building (permission applied for).

Other Pamphlets in this series

Church Windows maintenance, protection, repair, replacement

Church Organs care, conservation, repair and replacement

Gifts and Memorials twenty commemorative ideas

Working with an Architect getting the most from a partnership

Re-ordering Church Interiors space for a living church

Briefing the Artist commissioning a stained glass window

Sacramental Vessels heritage value, care, disposal

These can be obtained from:

**The Committee on Church Art and Architecture, 121 George Street,
Edinburgh EH2 4YN; tel 0131 225 5722 x359, fax 220 3113,
wordoc@cofscotland.org.uk.**

Comments and suggestions for inclusion in any revision of this pamphlet are welcomed.

CONTENTS

Introduction	4
What is 'disability'?	5
What the law says	6
Illustrations	8
Inside the building	10
Outside the building	12
Difficulties of implementation	14
Publications and addresses.....	15
Contacting the Committee	16

Additional notes

1 middle page UK Building Regulations state that the minimum standard of slope for a ramp or ramped up area is a 1:12 incline;

2 Railings A separate note on their design is available from the office.

3 Chairlifts and chair climbers Information about these alternative means of access is also available from the office.

INTRODUCTION

It is true that this pamphlet is to assist churches in complying with the provisions of the Disability Discrimination Act of 1995, but in reality it is as much about our continuing attempt to fulfil a much older duty of the Church, the provision of a ready welcome for 'all sorts and conditions' of people.

Jesus' ease with people who made others uncomfortable, embarrassed or threatened - because of accident of birth, health, or social status - is a pattern for the hospitality which is part of the declaration of the Gospel.

For us, therefore, the Act is not simply a piece of legislation to be conformed to but an opportunity to lead the local community into a fuller acceptance of those who for various reasons are, or feel, excluded.

WHAT IS 'DISABILITY'?

The popular term is 'disabled access' but a church which is open to all does not only have in mind those who have obvious physical disadvantages. We need to remember that there are many kinds of disability and that there are many stages in between full activity and severe impairment which are challenged by a building.

The Council for the Care of Churches guide, *Widening the eye of the needle* (see 'Publications and Addresses'), offers a useful definition when it says that 'a handicap results from the interaction of a person's disability with their environment'. As well as offering a reminder that the 'problem' is not with people but with the buildings in which they gather, it also acknowledges the variety of difficulties a person may have with a particular building.

Some, after a lifetime of faithful church attendance, just find the pews too unyielding; pains which are now part of daily life are exacerbated by long sits on shallow cushions against hard upright backs.

Some cannot go for long without visiting a toilet - and how many churches do not have any toilet facilities at all let alone ones which are handy and accessible?

It is not only older people who suffer in a church environment. People in later stages of pregnancy may give up coming to worship because there is nowhere they can withdraw to and perhaps lie down for a spell. Those with small children need a place to which to retreat if things get just too noisy. Those who are recovering from an illness or injury may require space for an injured leg. People who are very tall may feel cramped in the accommodation provided. Children may find too many obstacles or damaging protuberations.

Others are just not so good at handling books or money for offerings or Communion vessels. Some cannot concentrate for long periods. Some have learning difficulties. Others again may have a horror of being trapped in a long pew without an easy way of getting out.

However, what concerns a church which is serious about being genuinely 'inclusive' is not just the nature of the physical surroundings but many of the practices that we have taken for granted. The Disability Discrimination Act is not just about fabric but about programmes and procedures, and may challenge 'the way we have always done it'.

WHAT THE LAW SAYS

A very helpful document is the one circulated by the Church of Scotland's Law Department on the Disability Discrimination Act of 1995 (see 'Publications and Addresses') and the Department plans a further document as the implementation of the Act proceeds. Presbyteries have copies of these, and they can be acquired also from the Offices of the Church. This circular is quoted in what follows.

The Act of 1995 provided for three stages of implementation. To begin with, since December 1996 it has become unlawful for people to receive unfavourable treatment for a reason related to their disability. Then, from October 1999, 'service providers' had to make 'reasonable adjustments' in respect of disabled people in the way they offered these services. Finally, from 2004, these 'reasonable adjustments' will have to extend to the physical features of buildings.

How can we measure when it has become 'unreasonably difficult' (to quote another phrase from the legislation) for a person with a disability to gain access to and enjoy the benefits that are provided? A good guide would be whether the time, inconvenience, effort or discomfort entailed in using a service would be considered unreasonable by people in general if they had to endure similar difficulties.

It is perhaps best to explain this by giving some examples.

For those with visual impairment, many churches already provide hymn books in large print or in Braille. For many others, just good lighting would help. The way orders of service or parish newsletters are printed can make a difference. Black print on a white background is easiest to read; overprinting and unusual type faces can cause difficulty. Audiotaped versions could be provided. Another example is the desirability of highlighting hazards such as full length glazing, pillars, raised thresholds, mats, steps and stair nosings. (These are also helpful to ambulant disabled people with mobility difficulties.)

Another medium for information is the notice board. Small, badly written and presented notices do not help, but neither does the height at which they are often mounted, inconveniencing those of shorter stature, wheelchair users and children.

There are many stages on the way to deafness, some of which can be assisted by clear speaking and well-constructed sentences, others which require a loop system. The degree to which those who are leading the service are visible in all parts of the church is another factor. Seeing can help hearing. The height of the speaker is contributory. The voice has a better chance when its trajectory is not too near the heads (and clothing) of the congregation. Those who feel pulpits are out of date need to remember the purpose for which they were originally designed! Sign language may help some, as can the simple matter of providing pad and pencil at a tea stall.

Consider the use of a low dwarf wall to disguise the slope of the ramp

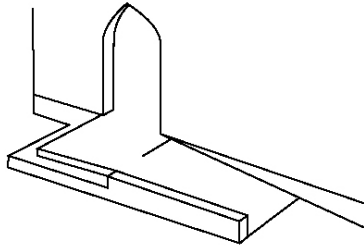
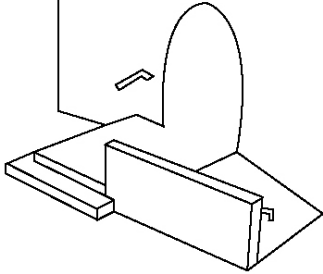

or perhaps a higher wall to which a simple handrail on brackets can be attached, or a horizontal railing and handrail

A railing that can be a work of craftsmanship in itself or an opportunity for improving lighting

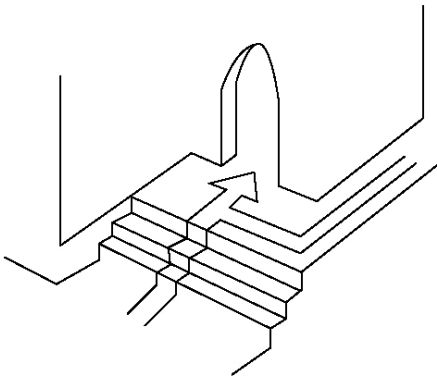
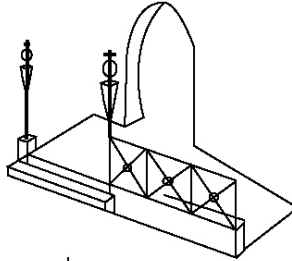

Create, if possible, a large enough level area on which to pause and even meet others before entering or leaving the building

should consideration be given to the need to maintain the symmetry of an imposing entrance

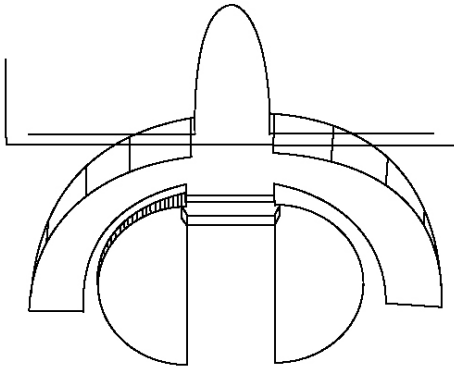
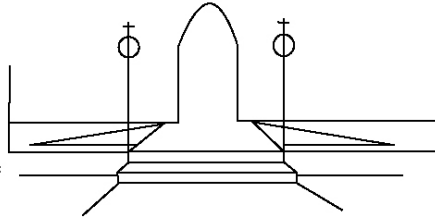

Can the arrangement add something useful to the building: a place to sit, or a garden

But try to avoid creating the impression that the minimum has been done to satisfy the need for easier access

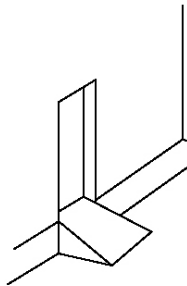

Perhaps it may be helpful to try to see the design of the new access through the eyes of the original architect and consider the way in which he or she would have designed this detail

Earlier paragraphs have acknowledged that people have many kinds of needs, and examples have been given as to how they may be met. Rooms to retreat to, space to move around for people who cannot sit long, access to well-positioned toilets which do not require a highly visible exit, perhaps through noisy doors - there are many adjustments that are not only 'reasonable' but not too difficult to achieve. A church in Milngavie, for example, has provided a 'comfort zone' for people with aches and pains who cannot sit too long in hard pews.

But there are also habits to be learned and unlearned. Looking directly at people when you speak to them allows those who can lip read to do so. Leaning on wheelchairs, moving them without asking first, failing to talk to the user directly, showing impatience with speech disorders, petting and feeding guide dogs without consent when they are working, all should be avoided. (Talking of which, consideration could be given to providing bowls of water for guide dogs, and seeing that there is access outside when required.)

There may also be attitudes that have to be changed. An example would be a greater tolerance on the part of older people in the congregation towards the noisier presence of children. Of course, things can 'cut both ways'. Sudden child noises can affect the nerves and disturb the hearing patterns of older people. Truly, creating a church that welcomes all comers is not a matter of some people providing for others, but for all of us learning to live with each other in community!

INSIDE THE BUILDING

We have already noted that from 2004, these 'reasonable adjustments' may need to have been carried out to the physical environment. It can be galling and disturbing to people who, used to making their own way, find themselves having to be helped to negotiate obstacles. It can be difficult for those who enjoy full mobility to appreciate the small setbacks of being forced to give up one's initiative and, for example, have to be lifted bodily up steps. In this, congregations need to bring their imagination into play, the better to see things from others' point of view.

What kind of adjustments might have to be made? Perhaps the most common request received by the Committee relates to the need to provide access for wheelchair users. There is no perfect arrangement for this and each situation has to be judged on its merits.

In many ways, the most desirable solution is for space to be created within the 'body of the kirk', perhaps by altering pews, rather than in a conspicuous 'segregated' area at the front. In such a case, it can be a good idea to shorten them rather than to remove them entirely so that those who accompany wheelchair users can sit with them in the same row. It might be better not just to shorten a pew on one side of the church but, for symmetry, to do so on the other side also. Alternatively, some congregations prefer to shorten pews at different places in the church so that wheelchair users have the same range of choice as is available to others.

A possible disadvantage, however, of offering wheelchair users room amongst the congregation is that they can feel hemmed in when everyone stands up to sing. In some buildings it may be possible to combine space in the 'body of the kirk' with good visibility towards the front of the church, and thus get the best of both worlds. Or a 'segregated' space to the side at the front may be the lesser of two evils. Consider making a chair or two available, if there are no contiguous pews, so that people can sit down to speak to wheelchair users.

In providing space for wheelchairs, it should also be borne in mind that wheelchair users may need to move around the church - for reading the lesson (if that is the practice in the church), or taking the offering, or officiating as elders at Communion. In this case, an additional ramp may need to be provided for access to the platform/chancel area. This need not go directly from the aisles but approach the platform in a circular movement out to the side, thus both preserving the step which defines the platform and giving access which is not on too steep a gradient.

Historic Scotland's *Access to our Built Heritage* reminds us of a number of related points. In thinking of wheelchair users, we should not forget that those who accompany them may often be weak or elderly themselves. What we provide must not assume that they will be accompanied by strong pushers. 'Nearly accessible is not really accessible'. Furthermore, once provisions are made, they should not be obscured, as when accessible lifts and toilets are used as store rooms!

Everything points to the need for each congregation to think the matter through in the context of its own unique building. The best thing is to listen to those who experience difficulties with the building and thus find out what is really needed.

OUTSIDE THE BUILDING

Of course, before entering the building other obstacles may be encountered. Many churches were built in the era before the car and it is often difficult to get a car near the front door. Might some special provision be made for those who have to come by car and who cannot easily walk any distance? Is there at least a setting down place as near the door as possible? Again, what of the surfaces between car park and door? Are they of gravel which impedes the smaller wheels of a wheelchair? Are there steps which have to be negotiated, or uneven paving slabs in which both wheels and feet may catch?

There are several questions which have to be borne in mind when constructing ramps leading to entrance doors. One relates to the desirability of not further segregating wheelchair users by so arranging things that only they would use the ramps. They should be as inviting to people, in their placing and construction, who are entering the church on foot.

Wherever possible, generous space should be provided so that users do not feel, whether making their way, or pausing to speak to others, that they are holding people up by their slower progress. Enough 'landing space' should also be provided at the top of ramps, so that people can recover from the effort of the gradient, with room for others to get round without jostling. Whenever possible a stepped access should also be available; not everyone can use a ramp.

There are also questions of appearance. How will the ramp look against the church itself? Will it look like an afterthought, or will it fit in with - or even enhance - the beauty of the building? Sadly, some existing examples dignify neither the building nor the users. Both the design and the materials matter. This is why the General Trustees, with the Artistic Matters Committee, need to approve these alterations. Members of the latter Committee are most willing to visit a church and give advice.

Inevitably, the question of cost can influence the choice of construction and a solution which does not involve masonry may be desirable. National Building Heritage organisations such as Historic Scotland and National Trust have devised lightweight timber and metal constructions which are appropriately designed for use in historic buildings and these solutions may be examined. Timber or galvanised metal solutions may be appropriate especially where alternative access is provided at the rear or side of a building and these should be detailed in a way that does not attract attention. Timber or metal framed solutions may terminate at a solid platform at the entrance to the building so that all worshippers may use the same final approach to the church.

It is always worth while getting an architect's help for both internal and external alterations. As well as ensuring that the correct specifications are adhered to (details on these can also be got from the local council's building control officers), it will help avoid making a change which would be uncomfortable to the eye and spoil the look of a much loved building. The centre page of this pamphlet shows some examples of good practice in installing ramps for better access.

DIFFICULTIES OF IMPLEMENTATION

There may be some circumstances where especial care is required in implementing this legislation, and some places where in the end the law has to be satisfied in another way.

Many churches are not simply places to worship but enshrine part of the history of church and nation. As well as responding to the needs of the living church they strengthen us with information and encouragement from the past - both regular users of a building and people in general. Accessibility is important, but where it is to be achieved only at the expense of destroying features which are part of the significance of the building, then one law has come into conflict with another. The law does not demand that everyone must always receive the 'services' provided in exactly the same way. Sometimes there may have to be 'equivalent provision'. Here, the Committee enter into very careful discussion with a congregation as to the best way of enabling better access in a particular case.

Another difficulty can be money. Although much of the work done on providing aids for disabled people is zero-rated for VAT, certain buildings may require a disproportionate sum of money to be spent. In such cases it may be necessary to think of other ways of providing better access - for example, in creating a 'partnership of buildings' where certain provisions are made in one that cannot be made in another. We have to remember that the law uses the term 'reasonable' - although we must be careful not to see this as a get out clause for the unenthusiastic! Again, the Committee can share the burden of decision with the local congregation.

Careful enquiry has revealed no public funds earmarked for this purpose or any charitable foundations which can offer help, although in the context of some programmes of wider refurbishment or conservation already being undertaken extra grants have been made available by the relevant body to this end. Certain local councils sometimes make grants but may turn churches down because they are not seen as being 'community organisations'. Local congregations should consider how far they contribute to the life of the local community in the widest sense and make this apparent in applications. The General Trustees can offer further advice if required and may in particular cases encourage an application to the Central Fabric Fund.

PUBLICATIONS AND ADDRESSES

Victory Young and Dennis Urquhart, *Access to the Built Heritage*, Technical Advice Note 7, Historic Scotland, Technical Conservation Group, Longmore House, Salisbury Place, Edinburgh EH9 1SH;

tel. 0131-668-638 fax: 0131 668-8669

www.historic-scotland.gov.uk

e-mail: hs.conservation.bureau@scotland.gsi.gov.uk

John Penton, *Widening the Eye of the Needle*, Church House Publishing, 2nd Edition. Available from the Council for the Care of Churches, Cathedral and Church Buildings Division, Church House, Great Smith Street, London, SW1P 3AZ Tel: 020 7898 1866 Fax: 020 7898 1881 www.churchcare.co.uk

Valuing Difference: People with Disabilities in the Life and Mission of the Church, published for the Catholic Bishops' Conference available online: www.catholic-ew.org.uk

The following two documents deal with the 'small print' of the Act. Those who wish to make further legal study will find them helpful. We have attempted to incorporate in this pamphlet any practical information they contain.

The Churches Main Committee (UK), Circular 1999/4, *Disability Discrimination Act 1995*, available from the Law Department, Church of Scotland, 121 George Street, Edinburgh EH2 4YN; tel. 0131 225 5722 ext. 234, fax 0131 220 3113.

Church of England Cathedrals Fabric Commission/Council for the Care of Churches, *Advisory Note: The Disability Discrimination Act 1995*, also available from the Law Department.

The Committee on Church Art and Architecture is based in the Church Offices in Edinburgh. It is staffed by the Rev Nigel Robb, Miss Lynn Johnson, Anna Reid and Ms Anne White. Its address and telephone number are: The Church of Scotland, 121 George Street, Edinburgh EH2 4YN, tel 0131 225 5722, fax 0131 220 3113. Faxes should be marked for the attention of the Committee. Email address is wordoc@cofscotland.org.uk. Extra copies of this pamphlet may be obtained from the office, price 50p.